

- Maintenance
- Overhaul
- Repair

! Attention during joining of modules in the bearing region.

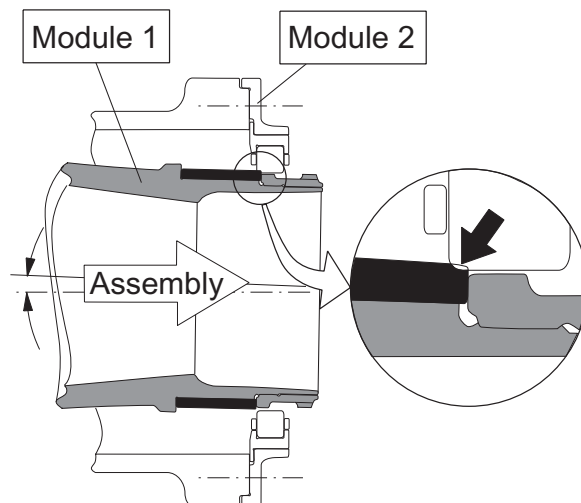
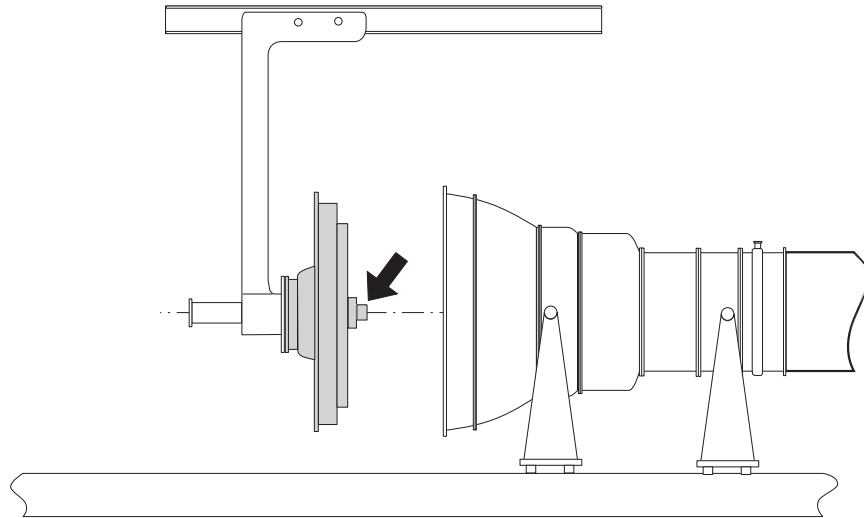

III. 4.2-5

III. 4.2-5 (example 4.2-6): In the context of assembly work during inspection and overhaul, the situation arises that **modules in the area of the bearing are joined**. Here the joints (arrow in Fig. above) may sometimes be insufficiently visible. If it has to do with the difficulty to move masses, there is the possibility that the bearing, e.g. through the edge of the rolling body is

damaged (arrow Fig. below). Such a damage can lead to fatigue of the raceway (spalling) and to failure of the bearing.

Thereby it is possible that the bearing fails so fast that this can not be captured or a fatigue failure (Ill. 3.5.1-10 and Ill. 3.5.1-11) can no more be identified during the formation of chips. In such cases it must be reckoned with extensive secondary damages.